



I care. You count. We matter.

Lessons Learned

Horizontal directional drilling pipe coil trailer

	Date and time of incident	27/04/2024 @ 16:30hrs	Incident type	Fatality
	Incident ref number	INC15523	Contractor	Harper Services Limited. Working for Morrison Utility Services
	Sublot	Sublot 5 South	Location	Middle Bickenhill Lane
	Keyword search	Directional Drilling with coiled ducting	Issued by	Neil Johnson, BBV Director of Health, Safety and Wellbeing



Summary of Incident

In April 2023, a colleague working on the HS2 Area North project received fatal injuries when he was struck by the end of a pipe coil as it was being fed from a coil trailer. The stored energy released during the unwind, caused the end of the pipe to come out of the side of the coil trailer with force.

Balfour Beatty VINCI have been working with others in the construction and utilities sector, including coil trailer manufacturers, trade associations and other Tier 1 contractors, to improve current industry standards. [Note 1] **As a result, the following timeline and actions must be followed.**



Actions

Before 31 July 2024

All direct and indirect supervisors and contractors involved in horizontal directional drilling (HDD) and using pipe coil trailers must be trained and briefed on the potentially fatal risk of stored energy from coiled pipe before arriving on site. This training must be recorded, and records made available for inspection, and checked as part of the setting people to work process.

All RAMS (Risk Assessment Method Statement) must be reviewed to ensure they include the hazards and appropriate control measures and are checked and signed at the point of work before work commences.

A safe system of work must be in operation at all times, including:

- Training on the RAMS, manufacturers' instructions, and safe systems of work.
- The mandatory use of ratchet straps and pipe end clamp (or equivalent) for the coil end of all 125mm diameter and above pipes.
- A permit system [Note 2].
- Completion of daily pre-start equipment checks.
- A red zone 'no entry' safety exclusion area of at least two metres around the entire base of the coil trailer (see diagram and table below).
- A clear safe system of work for cutting the coil straps in sequence and only while the coil is stationary.
- The use of energy dissipation devices and trailer side guarding if fitted.



Photographs

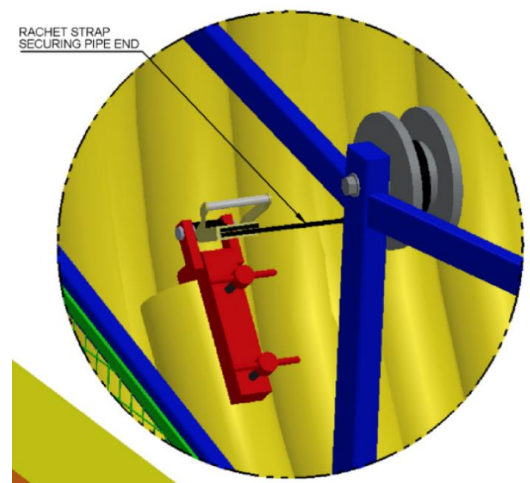



I care. You count. We matter.

Lessons Learned

Horizontal directional drilling pipe coil trailer

	Date and time of incident	27/04/2024 @ 16:30hrs	Incident type	Fatality
	Incident ref number	INC15523	Contractor	Harper Services Limited. Working for Morrison Utility Services
	Sublot	Sublot 5 South	Location	Middle Bickenhill Lane
	Keyword search	Directional Drilling with coiled ducting	Issued by	Neil Johnson, BBV Director of Health, Safety and Wellbeing

After 31 July 2024

In addition to RAMS including suitable information, instruction, training and supervision, and safe systems of work, **all coil trailers for 125mm diameter and above pipe coil must be fitted with:**

- Suitable ratchet straps and pipe end clamps and unobscured manufacturer safety decals.
- Fixed side guards for all four lower quadrants of the coil trailer.
- A device for dissipating the stored energy as the pipe is dispensed from the trailer.

Any coil trailer not fitted with the above requirements after 31 July 2024 must not be permitted to operate on any of our sites.

Notes:

1. The instructions in this alert are written to support the Prevention of future deaths.
2. Once we are assured that all training and risk control measures are embedded, and lessons learned have been shared, the requirement for a permit will be removed.
3. For smaller diameter pipe discharged from different types of coil trailer, guard and energy dissipation device modifications are not currently required as the stored energy is lower. The need for a safe system of work still applies, including adherence to the red exclusion zone.

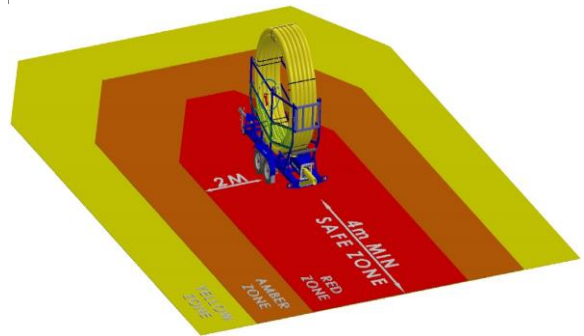

Distance of trailer to finishing point	Safe Zone
3M	4M
4M	5M
5M	6M
6M	7M

✓ **Actions Complete**

Please confirm using the QR code that all actions have been completed

